

REVISIONS					
REV.	DATE	ECN #	DESCRIPTION	BY	APP'D

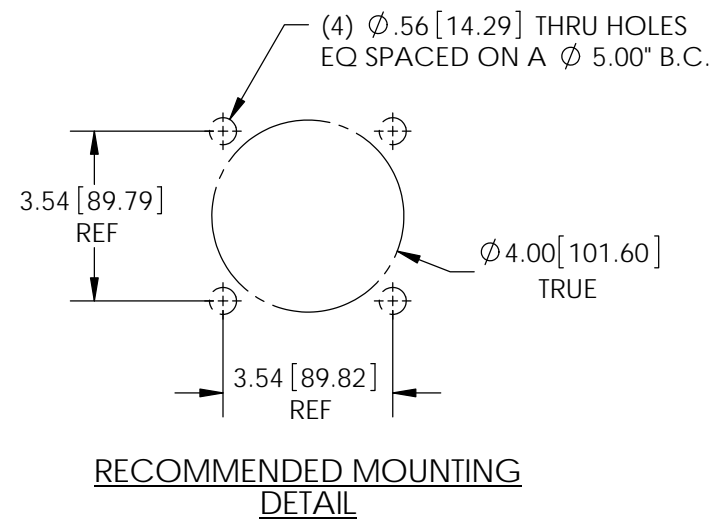

NOTES:
 1. ALL CONTACT SURFACES TO BE CLEAN & FREE FROM FLASH
MATERIAL:
 1. CYCLOALIPHATIC EPOXY (U.V. EXPOSED), COLOR: GREY
 2. HD ETP COPPER, C11000, TIN PLATED
 3. ANODIZED ALUMINUM NAMEPLATE
SPECIFICATIONS:
 1. MANUFACTURED IN ACCORDANCE WITH IEC 137-1995, CAN/CSA-C88.1-96, IEEE C57.19.01-1991
 2. RATED VOLTAGE38kV
 3. POWER FREQUENCY WITHSTAND80kV
 4. BASIC IMPULSE LEVEL200 kV
 5. NOMINAL CURRENT RATING1200 AMPS
 6. CREEP DISTANCE33"/838 mm (24 mm/kV)
 7. TEMPERATURE CLASSIFICATION-50°C TO +105°C
 8. APPROXIMATE WEIGHT50.5 LBS

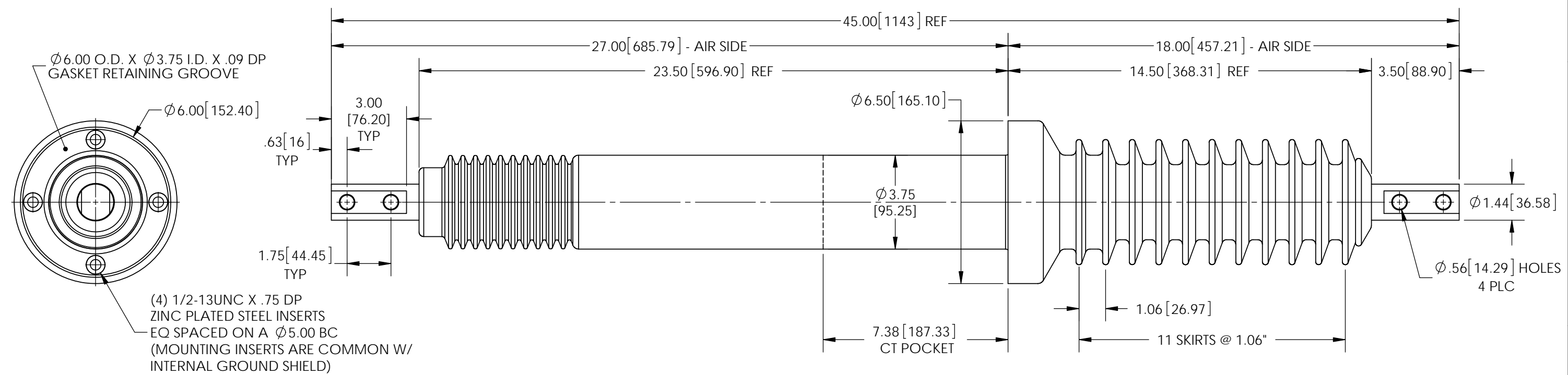
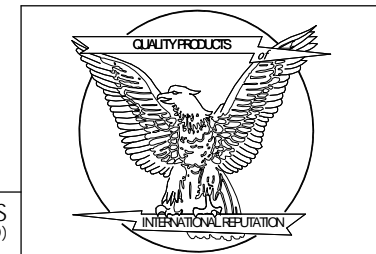

H-J INTERNATIONAL, INC.
 3010 HIGH RIDGE BLVD, HIGH RIDGE, MO. 63049 USA
 PHONE 1-636-677-3421 FAX 1-636-376-1915

POWER APPARATUS BUSHING
38kV / 1200A

PROPRIETARY AND CONFIDENTIAL THE INFORMATION CONTAINED IN THIS DRAWING IS THE SOLE PROPERTY OF H-J INTERNATIONAL, INC. ANY REPRODUCTION IN PART OR AS A WHOLE WITHOUT THE WRITTEN PERMISSION OF H-J INTERNATIONAL, INC. IS STRICTLY PROHIBITED.	TOLERANCES (EXCEPT AS NOTED) ONE PLACE MM ± 1.50 TWO PLACE MM ± 0.75 TWO PLACE DEC. $\pm .060$ THREE PLACE DEC. $\pm .030$ FRACTIONS $\pm 1/16$ " ANGLES 2°	APPROVED BY _____ DATE _____ CHECKED BY NS DATE 6/02/15 DRAWN BY TJF DATE 6/02/15 TOOL NO. T20-500-7 PRODUCT GRP. 2000 SERIES
	BREAK ALL SHARPS UNLESS OTHERWISE NOTED	DRAWING NO. 20-500-702 SCALE 1:4 SIZE B REV. SHEET 1 OF 1

DRAWING NO.	20-500-702		
SCALE	1:4	SIZE	B
REV.		SHEET	1 OF 1